

REVISED 4/1/2023

**SOLAR PHOTOVOLTAIC DISTRIBUTED GENERATION  
CUSTOMER GUIDELINES, APPLICATION & WGC INTERCONNECTION AGREEMENT**

**\*Do Not Install Until You Have Received Approved Plans From LID\***

INTRODUCTION

Lathrop Irrigation District has created a policy to allow safe connection and export from residential solar generators to the LID distribution system. At this time, LID will only allow applications for the addition of distributed solar photovoltaic generation systems as follows:

Residential Systems: Maximum size is 125% of house yearly kW demand or less with appropriate integral voltage conversion, synchronization, power quality, and protection circuitry.

Commercial Systems: Maximum size of twenty kilowatts (20 kW) or less with appropriate integral voltage conversion, synchronization, power quality, and protection circuitry.

Any request for a system size of larger than the maximum size of 20 kW will require an Engineering Study for review and approval of LID. The entire cost of the study will be borne by the applicant and payment of either a fee for review of a third party study or a non-refundable deposit for studies conducted by LID will be required. Please see page 6 for more information.

All Solar Photovoltaic Distributed Generation ("DG") systems must meet certain electrical criteria to be approved for connection to the LID distribution system. A list of pre-approved inverters may be found at:

<http://www.gosolarcalifornia.ca.gov/equipment/inverters.php>

A list of pre-approved PV modules may be found at:

[http://www.gosolarcalifornia.ca.gov/equipment/pv\\_modules.php](http://www.gosolarcalifornia.ca.gov/equipment/pv_modules.php)

Equipment not on the pre-approved lists are subject to review and approval of LID. A \$50 fee will be charged to you with your completed application; please see page 6 for fee information.

You must work with your contractor to ensure that your generation equipment is installed in a proper and safe manner, and in accordance with all applicable codes, standards, regulations, laws and insurance requirements. In many cases, you will also need to coordinate the installation and approval of your solar electric power generator with the local code inspection authority.

APPLICATION PROCESS

If you are planning to install solar photovoltaic ("PV") generators less than 20 kilowatts, please use the following process to complete the installation.

### Systems Not Proposed to be Interconnected to LID's Power System

If your small solar generator is not to be interconnected with LID's electric power system, all you need to do is give us a call, and provide us with the electrical capacity, manufacturer and name of your electrical installer. We may ask you to send us a copy of your manufacturer information and installation plans. There is no formal application or fee required, but you may use the LID "Application for Operation of Customer-Owned Solar Generation" form to provide information to LID. The system must be completely isolated from the LID electric distribution system under all circumstances.

### Systems Proposed to be Interconnected to LID's Power System

If you are planning to interconnect your generator with the LID electric power distribution system, you will need to complete the LID "Application for Operation of Customer-Owned Solar Generation" and submit it to us. You will also need to sign our LID "Agreement for Interconnection of Solar Photovoltaic Distributed Generation." Pages 5 & 6 contains details on the process and required review fees.

### *GENERATORS INTERCONNECTED WITH THE LID DISTRIBUTION SYSTEM*

When installing a solar PV generator which will interconnect with the LID distribution system, we must review your plans to ensure that LID personnel safety and LID electric system reliability will not be compromised.

Once we receive your application, LID will review your proposed solar PV generator installation. As part of LID's review of your "Application for Operation of Customer-Owned Solar Generation", we may request additional information regarding your planned installation and may require special steps be taken during the generator installation process.

You may contact our office at any time during this review process to find out the status of your application. If your application is not approved, LID will explain the reason or be available to discuss your plans. Please see page 3 for contact information.

As part of our application review process, LID will examine the ability of the LID electric distribution system to accept your new power generation unit. On certain parts of our system, LID may need to replace existing equipment or add some new equipment in order to accommodate your system's generation. In unusual circumstances, LID may not be able to configure its system to accept the generation and the application may be rejected.

If additional hardware is required, LID will incur costs beyond what is normally required to operate and maintain the system to benefit all of our customers. Therefore, to be fair to other customers, you may need to pay for any system upgrades that will be needed to support the addition of your planned solar PV generation.

If this is the case for your solar PV installation, LID will advise you of the additional cost, and seek your written agreement to pay these additional costs before approving your application. You will also be asked to sign the "System Upgrade Estimate" and the "Agreement for Interconnection of Solar Photovoltaic Distributed Generation", mentioned previously, in which you agree to operate your generator safely, maintain the unit properly, maintain insurance as needed, indemnify LID against liability incurred by ID as a result of your generator, and that obligates you to reimburse us for the

*EFFECTIVE: 4/1/2023*

additional expense incurred on your behalf. LID will furnish you an advance copy of the contract to review upon request.

### ***Technical Requirements***

The following are the minimum PV system interconnection requirements to ensure proper interface of single-phase 120 volt or 120/240 volt, photovoltaic systems with the LID system. These minimum requirements are based on IEEE Standards 1547 thru 1547.5, latest version. The Customer is responsible for complying with LID rules as outlined in its Operations Manual and Electric Service Requirements and all other applicable technical standards, safety codes, the National Electric Code, equipment manufacturers' specifications related to the design, installation, operation and maintenance of the customer's entire electrical installation including the PV system and any other applicable rules and regulations. The PV System and its components must be listed and tested by a National Recognized Testing Laboratory (NRTL) to Underwriters Laboratory (UL) Standard 1741. Please see next page for typical installation of equipment.

### ***Power Export to LID***

If you interconnect your solar PV generator with LID distribution system, you will provide all of the excess power that your system generates to LID with no charge to LID. LID does not currently wheel excess power for sale to other utilities. LID retains the right to refuse generation interconnection by any customer.

### ***Inspections Required***

- Electrical Inspection by the City of Lathrop.
- LID Commissioning Inspection – Upon receipt by LID of an approved electrical inspection by the City of Lathrop, a Commissioning Inspection will be conducted by LID staff solely to verify the system installed does not pose a safety threat to LID personnel. This is the FINAL step required PRIOR to connecting the Solar Electrical Generation to LID's grid.
- Any additional or re-inspections will be charged a \$75.00 trip fee, payable in advance.

**PLEASE NOTE:** LID is not responsible for the workmanship or materials of the Customer's installation contractor.

LID does not formally inspect the installation of your system. LID only verifies that your system meets LID safety standards for its personnel.

Submit your application and direct any questions to the following:

### **Solar Department**

P.O. Box 1397

Lathrop, CA 95330

Phone: (209) 888-4799

E-mail: solarinfo@lathropirrigation.com

# TYPICAL INSTALLATION SCHEMATIC

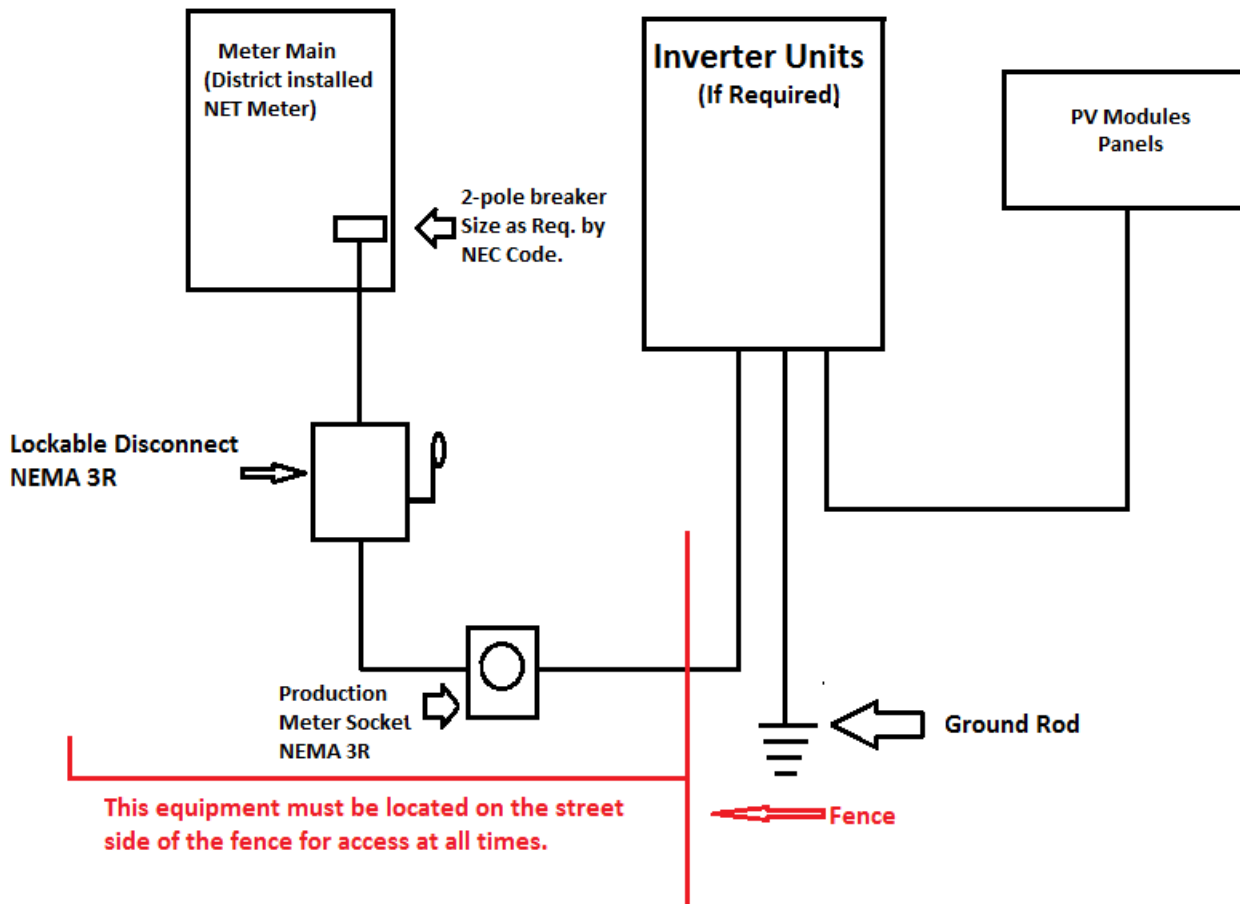

Revised 6/1/2017

CUSTOMER OWNED SOLAR GENERATION APPLICATION CHECKLIST

**Before submitting your application for Customer Owned Solar Generation, please make sure you have included the following items:**

- Executed Solar Photovoltaic Distributed Generation Customer Agreement
- Executed Application Form - with a check for applicable fee payment (see page 6)
- Be Sure on the Application to state Watts DC-STC and Watts DC
- Site Map & Plan
- One-Line Diagram Equipment Cut Sheet
- Copy of LID Utility Bill - for reference (N/A for New Builds)
- Contractor's Active License Number
- Applicable Fees Paid

**Once the Interconnection is approved, the Customer will receive a Letter of Approval for Interconnection from LID; it is the Customer's responsibility to contact their contractor of the approval. Once your system has been installed by your contractor, the following additional items are required prior to system start up:**

- Clearance from the City of Lathrop's Building Department
- Final Commissioning Inspection performed by LID

Final Commissioning Inspection is required PRIOR to connecting the solar electrical generation system to LID's electric grid. Owner and Installer are required to be present at the Commissioning Inspection. Once the Final Commissioning Inspection has been completed by LID to verify the size of the system which was installed by the Customer's contractor, installation of your Solar Electric Meter will be scheduled by LID.

**PLEASE NOTE:**

LID's Final Commission Inspection are solely to determine whether the system meets LID safety standards for its personnel and compatibility with LID's electric grid. LID is not responsible for, and has no control over the design, procurement of equipment, installation, commissioning or other construction related issues, all of which are solely the responsibility of the Customer.

## FEE SCHEDULE AND PAYMENT INFORMATION

### ALL REQUIRED FEES MUST BE PAID PRIOR TO YOUR APPLICATION BEING PROCESSED

The following fees are in effect as of May 1, 2018 and are subject to change at any time. Please contact LID for the latest fee schedule and payment information. Please make all checks out to "Lathrop Irrigation District."

Application Fee (required for all installations):	\$ 50
Plan Review Fee (required for all installations):	\$ 250
Final Commissioning Inspection Fee (Less than 20kW)	\$ 125
Solar Meter Charge	\$ 225
Final Commissioning Inspection Fee (20kW or greater)	\$ 500
Engineering Study Deposit (20kW Installations or greater only)*	\$1,000

\* - This deposit is required for all large installations and is non-refundable. If additional information or study is required prior to approval, additional fees may apply. Please contact LID for more information.

**APPLICATION FOR OPERATION OF CUSTOMER-OWNED  
SOLAR GENERATION LESS THAN 20KW**

***THIS APPLICATION SHOULD BE COMPLETED AS SOON AS POSSIBLE AND RETURNED  
TO LID IN ORDER TO BEGIN PROCESSING THE REQUEST***

Please see "SOLAR PHOTOVOLTAIC DISTRIBUTED GENERATION CUSTOMER GUIDELINES" for additional information regarding this application. LID uses this application to determine the required equipment configuration for the Customer interface. Every effort should be made to provide as much information as possible about your proposed system.

**PART 1**

<b>SERVICE LOCATION</b>		
Address:		
City:	State:	Zip Code:
Assessor's Parcel Number:		

<b>OWNER/APPLICANT INFORMATION</b>		
Customer Name:		
Mailing Address (if different from above):		
City:	State:	Zip Code:
Phone Number:		
Email Address:		

<b>PROJECT DESIGNER (ENGINEER/ARCHITECT)</b>		
Company Name:		
License Number and State:		
Mailing Address:		
City:	State:	Zip Code:
Phone Number:		
Email Address:		
Representative's Name:		

**PART 1 (CONTINUED)**

<b>ELECTRICAL CONTRACTOR</b>		
<b>Company Name:</b>		
<b>License Number and State:</b>		
<b>Mailing Address:</b>		
<b>City:</b>	<b>State:</b>	<b>Zip Code:</b>
<b>Phone Number:</b>		
<b>Email Address:</b>		
<b>Representative's Name:</b>		

<b>ESTIMATED LOAD, GENERATOR RATING AND MODE OF OPERATION INFORMATION</b>		
<i>The following information will be used to help properly design the LID customer interconnection. This information is not intended as a commitment or contract for billing purposes.</i>		
<b>Annual Site Usage:</b>		<b>kWH</b>
<b>Annual Estimated Generation:</b>		<b>kWH</b>
<b>System KW-STC-DC:</b>		<b>kW</b>
<b>System KW-AC:</b>		<b>kW</b>
<b>Mode of Operation (circle one)</b>	<b>Isolated</b>	<b>Interconnect Power Export</b>
<b>Inverter Rating:</b>		<b>kW</b>
<b>Module Manufacturer:</b>		<b>Model Number:</b>
<b>Number of Modules:</b>		

<b>DESCRIPTION OF PROPOSED INSTALLATION AND OPERATION</b>		
<i>Please give a general description of the proposed installation, including planned location, timing of installation and expected date of initial operation. Use additional sheets if necessary.</i>		



**PART 2**

In addition to the items provided above, please attach a detailed one-line diagram of the proposed facility, all applicable elementary diagrams, major equipment (generators, transformers, inverters, circuit breakers, protective relays, etc., as well as specifications, test reports and any other applicable drawings or documents necessary for the proper design and installation of the proposed interconnection. Please copy this page for as required for additional generators.

**INVERTER DATA** (if applicable)

Manufacturer: \_\_\_\_\_ Model: \_\_\_\_\_

**PART 3**

**SIGNATURE AND DISCLOSURE**

The Customer understands and acknowledges that LID's Commissioning Inspection and/or other reviews of the proposed installation are solely to determine whether the system meets LID safety standards for its personnel and compatibility with LID's system requirements. LID is responsible for and has no control over the design, procurement of equipment, installation, commissioning or other construction related issues, all of which are solely the responsibility of the Customer. By signing this application, Customer (DG Owner/Operator) agrees to indemnify, defend, and hold LID harmless from any and all claims, losses, costs and expenses (including, without limitation, attorneys' fees and other legal costs incurred by LID), arising out of or resulting from the proposed installation as described herein, along with any other equipment or facilities interconnected to the LID electrical system.

The Customer agrees to provide LID with any additional information required to complete the proposed Interconnection. The Customer agrees and warrants that he/she shall operate his equipment within the Guidelines set forth by LID. Further, Customer understands and acknowledges that LID is not responsible for the workmanship or materials of the Customer's installation contractor.

\_\_\_\_\_  
Applicant Name – Please Print

\_\_\_\_\_  
Signature

\_\_\_\_\_  
Applicant Name – Please Print

\_\_\_\_\_  
Signature

\_\_\_\_\_  
Date

\_\_\_\_\_  
Date

**WGC INTERCONNECTION AGREEMENT FOR  
SOLAR PHOTOVOLTAIC DISTRIBUTED GENERATION**

***THIS AGREEMENT MUST ACCOMPANY YOUR SIGNED APPLICATION  
AND PAYMENT OF REQUIRED FEES***

This Wholesale Generation Credit (WGC) Interconnection Agreement ("Agreement") is made and entered into this day of 20\_\_ by Lathrop Irrigation District, ("LID"), and

\_\_\_\_\_  
(Print Customer Name), a Solar Photovoltaic Distributed Generation Owner / Operator ("DG Owner / Operator"), each hereinafter sometimes referred to individually as "Party" or both referred to collectively as the "Parties". In consideration of the mutual covenants set forth herein, the Parties agree as follows:

This agreement provides for the safe and orderly operation of the electrical facilities interconnecting the DG Owner / Operator's facility at service location stated below and the electrical distribution facility owned by LID.

Service Location: \_\_\_\_\_  
Type of Service:      Residential      OR      Small General Service (circle one)

This Agreement does not supersede any requirements of any by-laws, applicable tariffs, rates, rules and regulations in place between the DG Owner / Operator and LID.

**1.0 Intent of Parties:** It is the intent of (the DG Owner / Operator) to interconnect a solar photovoltaic electric power generator to LID's electrical distribution system in order to offset electric power supplied by LID.

**1.1** It is the intent of LID to operate the LID distribution system to maintain a high level of service to their customers and to maintain a high level of power quality.

**1.2** It is the intent of both parties to operate the DG facilities in a way that ensures the safety of the public and the LID employees.

**1.3** LID gives no guarantee, written or otherwise implied, that the DG Owner will or will not realize an economic benefit through the interconnection of a PV system.

**2.0** Purchase of energy generated by PV system.

**2.1** LID will purchase any energy generated by Customer's PV system into the LID system beyond the usage at the Customer site on a monthly basis. Generation of more than the customer's monthly usage shall be calculated at the LID's Tariff Rate (which is subject to amendment) and applied to the customer's account per the Wholesale Generation Credit (WGC).

**3.0 Purchase of Energy from LID.**

**3.1** Energy consumed by the customer and recorded by LID's meter shall be billed to the DG Owner at the standard rates established by LID.

## **4.0 General Requirements.**

**4.1** The following PV system interconnection requirements by LID are the minimum requirements to ensure proper interface of single-phase 120 volt or 120/240 volt, photovoltaic systems with LID. The minimum requirements are based on the IEEE Standard 1547.1 thru 1547.5, latest version. The Customer is responsible for complying with LID's rules and all other applicable technical standards, safety codes, the National Electric Code, and the equipment manufacturers' specifications related to the design, installation, operation and maintenance of the customer's entire electrical installation including the PV system, not specifically mentioned in the document. The PV Inverter System and its Components must be Listed and Tested by a National Recognized Testing Laboratory (NRTL) to Underwriters Laboratory (UL) Standard 1741. A list of equipment having such NRTL listing may be found at websites contained in the "SOLAR PHOTOVOLTAIC DISTRIBUTED GENERATION CUSTOMER GUIDELINES"

**4.2** Equipment shall be installed in accordance with NEC

**4.2.1** Disconnect switches shall comply with NEC 690-17 and will have a sign reading: "WARNING – ELECTRIC SHOCK HAZARD - DO NOT TOUCH - TERMINALS ON BOTH THE LINE AND LOAD MAY BE ENERGIZED IN OPEN POSITION"

**4.2.2** Breaker will be labeled "PHOTOVOLTAIC POWER SOURCE" per NEC 705 and "BREAKERS ARE BACKFED" per NEC 690-64(b)5.

**4.2.3** Label "PHOTOVOLTAIC SYSTEM KWH METER."

**4.2.4** "CO-GENERATION SYSTEM UTILITY DISCONNECT SWITCH" shall be provided and installed by DG Owner. The DG Owner shall install a LID-accessible, outdoor-mounted, load- break disconnect switch with a visible open that is capable of being padlocked in the open position by LID personnel. The disconnect switch shall be mounted near the service entrance next to the main meter and before the LID production meter. It shall be properly grounded and clearly labeled "PHOTOVOLTAIC SYSTEM UTILITY DISCONNECT". The disconnect switch shall be installed on the alternating current (AC) circuit between LID and AC input to the inverter. The purpose of the disconnect switch is for LID personnel to disconnect the PV system from LID to eliminate all potential sources of back feed when it is necessary to safely work on local area power lines or equipment. The DG Owner understands that LID has the right to padlock the disconnect switch in the open position at any time without notice to the Customer. The DG Owner also understands not to tamper with or remove the padlock if the disconnect switch is padlocked in the open position by LID. The disconnect switch must be installed by a licensed electrician and inspected as set forth in this document.

**4.2.5** The PV array safety disconnect will be marked with PV source rating per NEC 690.53 including short circuit current.

**4.2.6** The DG Owner, through its Electrical Contractor shall have an electrical building inspection performed by the agency having authority

**4.2.7** The DG Owner shall have a commissioning inspection performed by LID. The inspection is solely to determine if the equipment has appropriate UL listings and does not represent a safety hazard to LID personnel.

**5.0 Conditions Precedent**

**5.1** The customer is required to provide a meter socket and pay for any additional meters required due to the Solar DG. Typically, a meter is required for incoming service from LID, and a separate production meter is required for generated power from the Solar DG.

**5.2** An "Application for Operation of Customer-Owned Solar Generation" with the customer shall be required for service under this rider. Solar customers are also required to sign the interconnection agreement.

**5.3** The customer shall pay LID for interconnection costs prior to commencement of service under this rider. Interconnection costs may include but are not limited to reasonable costs of connection, switching, relaying, metering, safety provisions, engineering studies and administrative costs incurred by LID directly related to the installation of the physical facilities necessary to permit interconnected operations. An estimate of these costs will be provided to the customer following their completed "Application for Operation of Customer-Owned Solar Generation".

**6.0 Operating Authority**

The DG Owner / Operator is responsible for understanding operating procedures and standards for the solar photovoltaic system. The DG Owner / Operator is responsible for operating and maintaining the generator facility in accordance with all applicable safety and electrical codes, applicable laws, and LID operational standards.

LID shall ensure that the DG Owner / Operator is aware of the provisions of any applicable LID operating procedures and regulations relating to the safe operation of the LID electrical power system.

The operating authority for the DG Owner / Operator is:

Name: \_\_\_\_\_  
Mailing Address: \_\_\_\_\_  
Phone Number: \_\_\_\_\_  
Email Address: \_\_\_\_\_

**7.0 Suspension of Interconnection**

It is intended that the interconnection should not compromise LID's protection or operational requirements. The operation of the DG Owner / Operator's System and the quality of electric energy supplied by DG Owner / Operator shall meet the standards as specified by LID. If the operation of the DG Owner / Operator's system or quality of electric energy supplied (in the case of power export) does not meet the standards as specified, then LID will notify DG Owner / Operator to take reasonable and expedient corrective action. LID shall have the right to disconnect the DG Owner / Operator's System, until compliance is reasonably demonstrated. Notwithstanding, LID may in its sole discretion disconnect the DG Owner / Operator's generating plant from the Distribution Facility without notice if the operation of the Generating Plant imposes a threat, in LID's sole judgment, to life or property.

**8.0 Billing**

**8.1** WGC Metering service is provided in accordance with the terms of LID's Tariffs, including any amendments. Billing under WGC Metering arrangement will apply monetary credits to the

*EFFECTIVE: 4/1/2023*

customer's monthly statement for excess monthly generation and deducted from the current charges. If the monthly credits is greater that the monthly statement the remaining credits will roll over into the next month. Any excess annual energy generated is greater than the yearly charges will be trued up annually and paid per the WGC payment agreement.

## **9.0 Green Credits**

**9.1** Title to and ownership of any and all environmental / green credits associated with Customer-Owned Solar Generation PV System shall pass from DG Owner to LID upon initiation of service and LID shall maintain title to and ownership of all such environmental / green credits, benefits, emissions reductions, offsets and allowances, howsoever entitled, attributable to the generation of energy from the Solar Generation PV System. The calculation, use and retirement of any and all environmental/green credits shall be in the sole and exclusive discretion of LID.

## **10.0 Maintenance Outages**

**10.1** Maintenance outages will occasionally be required on LID's system, and the LID will provide as much notice and planning as practical to minimize downtime. It is noted that in some emergency cases such notice may not be practical. Compensation will not be made for unavailability of LID's facilities due to outages.

## **11.0 Access**

**11.1** Access is required at all times by LID to the DG Owner / Operator's plant site for maintenance, operating and meter reading. LID reserves the right, but not the obligation, to inspect the DG Owner / Operator's facilities at any reasonable time.

## **12.0 Liability and Indemnification**

**12.1** DG Owner / Operator shall assume all liability for and shall indemnify LID for any claims, losses, costs, and expenses of any kind or character to the extent that they result from DG Owner / Operator's negligence or other wrongful conduct in connection with the design, construction or operation of DG Owner / Operator's facility.

**12.2** LID SHALL NOT BE LIABLE FOR ANY ACTIONS OR OMISSIONS IN ITS PERFORMANCE OF THESE INTERCONNECTION REQUIREMENTS UNLESS CAUSED BY LID's GROSS NEGLIGENCE OR WILLFUL MISCONDUCT. IN NO EVENT SHALL LID, ITS BOARD MEMBERS, ITS MANAGERS, EMPLOYEES OR AGENTS BE LIABLE TO THE CUSTOMER FOR LOSS OR PROFITS OR ANY OTHER SPECIAL, INDIRECT OR CONSEQUENTIAL DAMAGE, HOWEVER CAUSED, RESULTING FROM LID's PERFORMANCE HEREUNDER.

## **13.0 Term**

**13.1** This document is intended to be valid for the period of time that the DG Owner / Operator's system is connected to LID's distribution system. It may be canceled by either party with not less than 30 days' notice to the other party. The DG Owner / Operator's system will be disconnected from LID's system if the contract is canceled.

**14.0 Governing Law and Attorney's Fees**

This Agreement shall be governed by the State of California laws.

**15.0 Successors and Assignment.**

This agreement is and shall be binding on all successors and assigns of each of the parties hereto without the necessity of any further documentation.

\*\*\*\*\*

**AGREED TO BY:**

**DG OWNER / OPERATOR:**

**LATHROP IRRIGATION DISTRICT**

Print Name: \_\_\_\_\_

Print Name: \_\_\_\_\_

Address: \_\_\_\_\_

Title: \_\_\_\_\_

Signature: \_\_\_\_\_

Signature: \_\_\_\_\_

Date: \_\_\_\_\_

Date: \_\_\_\_\_